

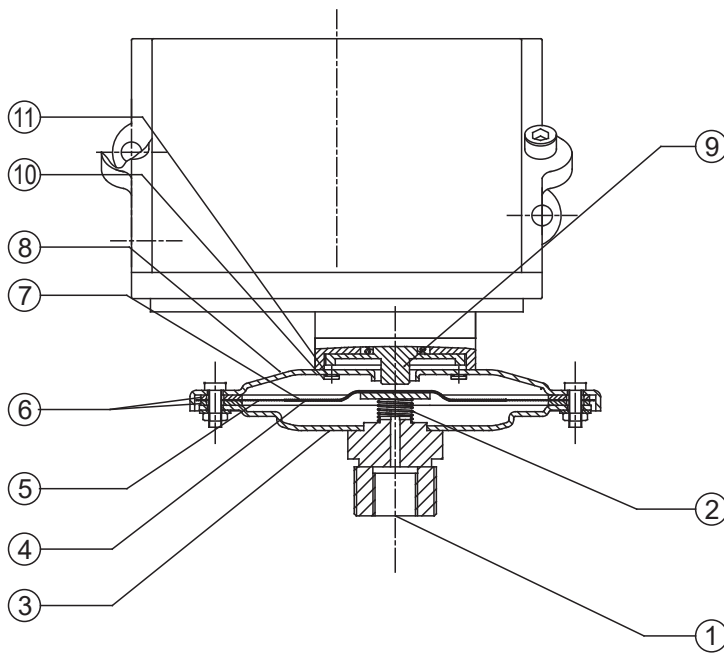

MT

CE

**PRESSURE CAPSULE DETAILS**



**No. Description**

- 1. Pressure Port (SS)
- 2. Support Spring (SS)
- 3. Bottom Flange (SS)
- 4. Support Plate (Al)
- 5. Diaphragm (Neoprene)
- 6. Gasket (PTFE)
- 7. Top Plate (Aluminium)
- 8. Top Flange (SS)
- 9. Plunger
- 10. Top Flange Screw (SS)
- 11. Sealing O-Ring (Nitrile)

Note : *wetted parts* are mentioned in italics.

\*Pressure ports are brazed with flange

**INSTALLATION DRAWING**

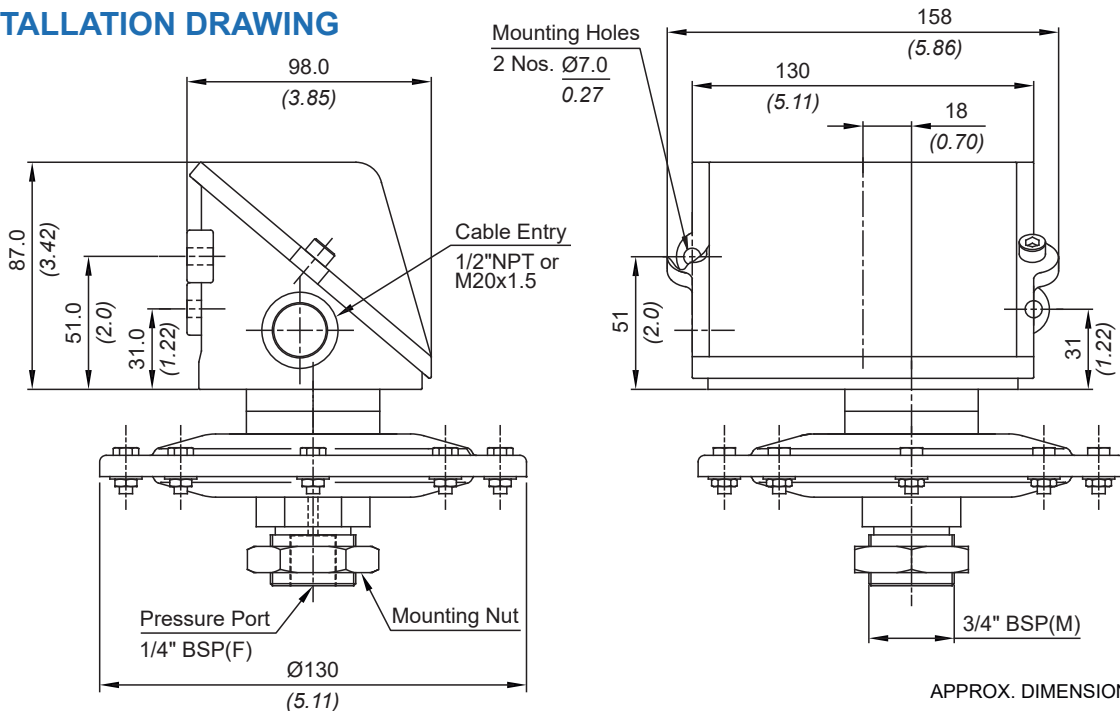

**RANGE SELECTION TABLE**

Range Code	Range mm wc ("wc)	Differential* mm wc ("wc)	Maximum Working Pressure bar (psi)
		Approximate Maximum for "A1" microswitch	
CL2	-150 to 150 (-5.905 to 5.905)	40.0 (1.605)	2.0 (29.00)
CL3	-250 to 250 (-9.842 to 9.842)	60.0 (2.410)	2.0 (29.00)
CL5	-500 to 500 (-19.685 to 19.685)	100.0 (3.937)	2.0 (29.00)
CLX	-100 to 100 (-3.937 to 3.937)	150.0 (5.90)	2.0 (29.00)

Note:

1. The minimum differential increases with the setpoint. The differential values mentioned in the above table are approximate maximum for FSR. The differential value will vary according to the pressure range selected and microswitch type. For actual values of differential please contact sales office.

2. When using 2SPDT switching arrangement, both microswitches may not actuate and/or deactuate at the same point. A small stage gap, normally upto +/- 5% FSR (depending on range code) may be observed. The On-Off differential (hysteresis) typically tends to be atleast double of those published for 1SPDT pressure switches.

If actuation and/or deactuation at same point is critical part of operation, then it can be achieved by using a separate DPDT relay. This relay will need a separate power supply for it's coil.

HOW TO ORDER INDUSTRIAL LOW RANGE COMPOUND SWITCHES

Group 1	Group 2	Group 3	Group 4	Group 5	Group 6	Group 7	Group 8								
Non standard allocation	Gas Group Classification	Cable Entry Size	Switch Type	Range Code (values in mm wc)	Microswitch Type	Pressure Port Material / Size	Diaphragm								
<input type="checkbox"/> A prefix "N" is used in the model code in case of any non standard options / accessories that are provided with the switches. Will be given by manufacturer, only after agreement of supply details with customer.  The prefix is subject to change as per specific requirement.	<b>MD</b> = Industrial pressure switch with IP66 rated enclosure as per IS/IEC 60529  <b>MT</b> = Industrial pressure switch with IP66 rated enclosure as per IS/IEC 60529	<b>1</b> = Al. enclosure 1/2" NPT threads <b>*2</b> = Al. enclosure 3/4" NPT threads <b>3</b> = Al. enclosure M20 X 1.5 threads <b>7</b> = SS enclosure, 1/2" NPT threads <b>*8</b> = SS enclosure, 3/4" NPT threads <b>9</b> = SS enclosure, M20 X 1.5 threads	<b>CF1</b> = Compound switch, fixed differential without scale  <b>CF2</b> = Compound switch, fixed differential with scale in bar  <b>*CA1</b> = compound switch, adjustable differential without scale <b>*CA2</b> = compound switch, adjustable differential with scale in bar	<b>CL2</b> = (-150 to 150) <b>CL3</b> = (-250 to 250) <b>CL5</b> = (-500 to 500) <b>CLX</b> = (-100 to 100)	<b>A1</b> = General purpose microswitch, rated at 15 A; 250 VAC <b>*A6</b> = Adjustable deadband <b>*A7</b> = 2SPDT switching elements <b>*A8</b> = General purpose microswitch <b>*A9</b> = General purpose microswitch <b>*B7</b> = 2SPDT Switching Elements <b>*B9</b> = 2SPDT Switching Elements for adjustable differential	<b>S1</b> = SS316 / 1/4" BSP(F) <b>S2</b> = SS316 / 1/4" NPT(F)  More options available, please contact sales office	<b>0</b> = Neoprene <b>1</b> = PTFE <b>2</b> = SS 316L								
Approx. switch weight in Kgs <table border="1"> <thead> <tr> <th>Enclosure</th> <th>MD</th> <th>MT</th> </tr> </thead> <tbody> <tr> <td>Aluminium</td> <td>1.500</td> <td>1.904</td> </tr> <tr> <td>SS</td> <td>3.080</td> <td>3.510</td> </tr> </tbody> </table>		Enclosure	MD	MT	Aluminium	1.500	1.904	SS	3.080	3.510	*Not available for MT model For dual cable entry contact Sales Office	*Available with A6, A7, A9 & B9 (in group 6) only	* Please refer to page nos. 290 & 291 for options and specifications of microswitches Please contact sales office for additional information	For additional wetted parts please contact sales office	
Enclosure	MD	MT													
Aluminium	1.500	1.904													
SS	3.080	3.510													

eg. An industrial switch for gas group IIC, with 1/2" NPT cable entry in aluminium housing as 1SPDT pressure switch, having -150 to 150 mm wc pressure range, with 15 Amp. microswitch, SS316 pressure housing with 1/4" BSP port size & neoprene diaphragm shall be specified by

Group 1	Group 2	Group 3	Group 4	Group 5	Group 6	Group 7	Group 8
<input type="checkbox"/>	MD	1	CF1	CL2	A1	S1	0

Please specify full model number to avoid ambiguity. If only the first two groups are specified while ordering, uncalibrated switches with standard wetted parts and enclosures will be supplied.

© 09/2025 WEISZ. All rights reserved.  
 The information included reflects the current state of development at the time of publication.  
 Due to continuous product improvement, specifications are subject to change without notice.