

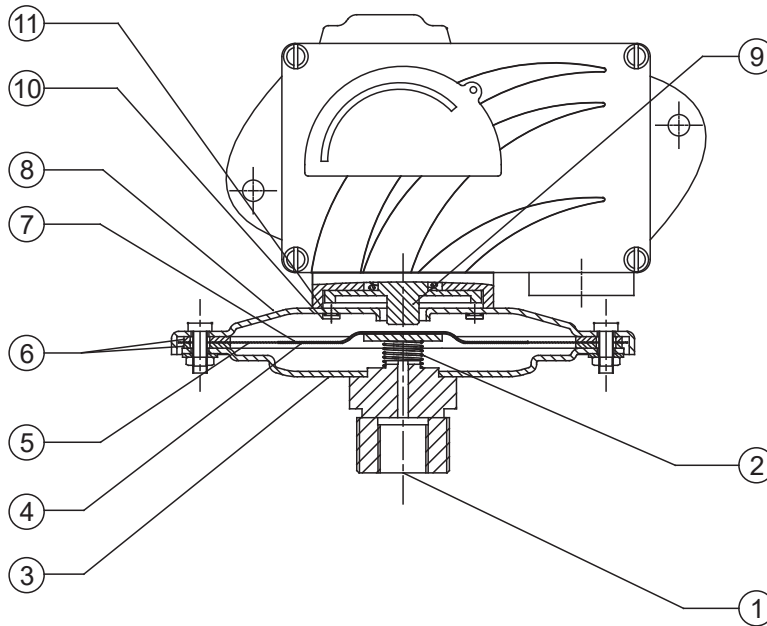

MD

CE

PRESSURE CAPSULE DETAILS



No. Description

- 1. Pressure Port (SS)
- 2. Support Spring (SS)
- 3. Bottom Flange (SS)
- 4. Support Plate (Al)
- 5. Diaphragm (Neoprene)
- 6. Gasket (PTFE®)
- 7. Top Plate (Aluminium)
- 8. Top Flange (SS)
- 9. Plunger (SS)
- 10. Top Flange Screw (SS)
- 11. Sealing O-Ring (Nitrile)

Note : *wetted parts* are mentioned in italics.

*Pressure ports are brazed with flange

INSTALLATION DRAWING

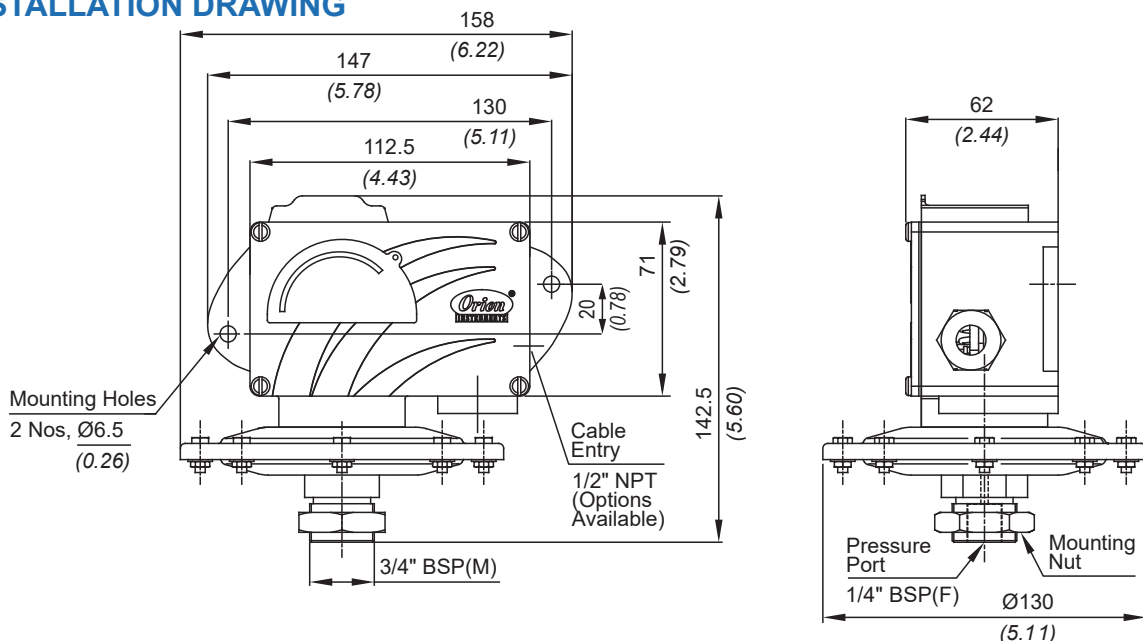

APPROX. DIMENSIONS IN $\frac{\text{mm}}{\text{inches}}$

RANGE SELECTION TABLE

Range Code	Range mbar ("wc)	Differential* mbar ("wc)	Maximum Working Pressure bar (psi)
		Approximate Maximum for "A1" microswitch	
L02	1.5 - 15.0 (0.602 - 6.021)	3 (1.204)	2 (29.00)
L03	5.0 - 25.0 (2.007 - 10.037)	5 (2.007)	2 (29.00)
L05	10.0 - 50.0 (4.015 - 20.073)	5 (2.007)	2 (29.00)
L10	10.0 - 100.0 (4.015 - 40.146)	10 (4.015)	2 (29.00)
L15	10.0 - 150.0 (4.015 - 60.22)	15 (6.027)	2 (29.00)
L25	20.0 - 250.0 (8.029 - 100.36)	20 (8.037)	2 (29.00)
L35	50.0 - 350.0 (20.073 - 140.52)	25 (10.036)	2 (29.00)

Note:

1. The minimum differential increases with the setpoint. The differential values mentioned in the above table are approximate maximum for FSR. The differential value will vary according to the pressure range selected and microswitch type. For actual values of differential please contact sales office.

2. When using 2SPDT switching arrangement, both microswitches may not actuate and/or deactuate at the same point. A small stage gap, normally upto +/- 5% FSR (depending on range code) may be observed. The On-Off differential (hysteresis) typically tends to be atleast double of those published for 1SPDT pressure switches.

If actuation and/or deactuation at same point is critical part of operation, then it can be achieved by using a separate DPDT relay. This relay will need a separate power supply for it's coil.

HOW TO ORDER INDUSTRIAL LOW RANGE PRESSURE SWITCHES

Group 1	Group 2	Group 3	Group 4	Group 5	Group 6	Group 7	Group 8								
Non standard allocation	Model	Cable Entry Size	Switch Type	Range Code (values in mbar)	Microswitch Type	Pressure Port Material / Size	Diaphragm								
<p><input type="checkbox"/> A prefix "N" is used in the model code in case of any non standard options / accessories that are provided with the switches. Will be given by manufacturer, only after agreement of supply details with customer.</p> <p>The prefix is subject to change as per specific requirement.</p>	<p>MD = Industrial pressure switch with IP66 rated enclosure as per IS/IEC 60529</p> <p>MT = Industrial pressure switch with IP66 rated enclosure as per IS/IEC 60529</p>	<p>1 = Al. enclosure 1/2" NPT threads</p> <p>*2 = Al. enclosure 3/4" NPT threads</p> <p>3 = Al. enclosure M20 X 1.5 threads</p> <p>7 = SS enclosure, 1/2" NPT threads</p> <p>*8 = SS enclosure, 3/4" NPT threads</p> <p>9 = SS enclosure, M20 X 1.5 threads</p>	<p>PF1 = pressure switch, fixed differential without scale</p> <p>PF2 = pressure switch, fixed differential with scale in mbar</p> <p>PF3 = pressure switch, fixed differential with scale in "Wc</p> <p>*PA1 = pressure switch, adjustable differential without scale</p> <p>*PA2 = pressure switch, adjustable differential with scale in mbar</p> <p>*PA3 = pressure switch, adjustable differential with scale in "Wc</p>	<p>L02 = (1.5 - 15)</p> <p>L03 = (5 - 25)</p> <p>L05 = (10 - 50)</p> <p>L10 = (10 - 100)</p> <p>L15 = (10 - 150)</p> <p>L25 = (20 - 250)</p> <p>L35 = (50 - 350)</p>	<p>A1 = General purpose microswitch, rated at 15 A; 250 VAC</p> <p>*A6 = Adjustable deadband</p> <p>*A7 = 2SPDT switching elements</p> <p>*A8 = General purpose microswitch</p> <p>*A9 = General purpose microswitch</p> <p>*B7 = 2SPDT Switching Elements</p> <p>*B9 = 2SPDT Switching Elements for adjustable differential</p> <p><small>* Please refer to page nos. 290 & 291 for options and specifications of microswitches Please contact sales office for additional information</small></p>	<p>S1 = SS316 / 1/4" BSP(F)</p> <p>S2 = SS316 / 1/4" NPT(F)</p> <p><small>More options available, please contact sales office</small></p>	<p>0 = Neoprene</p> <p>1 = PTFE</p> <p>2 = SS316L</p> <p><small>More options available. Please contact sales office.</small></p>								
<p>Approx. switch weight in Kgs</p> <table border="1"> <thead> <tr> <th>Enclosure</th> <th>MD</th> <th>MT</th> </tr> </thead> <tbody> <tr> <td>Aluminium</td> <td>1.500</td> <td>1.980</td> </tr> <tr> <td>SS</td> <td>3.100</td> <td>3.570</td> </tr> </tbody> </table>		Enclosure	MD	MT	Aluminium	1.500	1.980	SS	3.100	3.570	<p><small>*Not available for MT model For dual cable entry contact Sales Office</small></p>	<p><small>*Available with A6, A7, A9 & B9 (in group 6) only</small></p>	<p><small>* Please refer to page nos. 290 & 291 for options and specifications of microswitches Please contact sales office for additional information</small></p>	<p><small>More options available, please contact sales office</small></p>	<p><small>More options available. Please contact sales office.</small></p>
Enclosure	MD	MT													
Aluminium	1.500	1.980													
SS	3.100	3.570													

eg. A low range industrial switch, with 1/2" NPT cable entry in aluminium housing as 1SPDT pressure switch, fixed differential without scale, having 5 mbar to 25 mbar pressure range, with 15 Amp. microswitch, SS316 pressure housing with 1/4" BSP port size & neoprene diaphragm shall be specified by

Group 1	Group 2	Group 3	Group 4	Group 5	Group 6	Group 7	Group 8
<input type="checkbox"/>	MD	1	PF1	L03	A1	S1	0

Please specify full model number to avoid ambiguity.

© 09/2025 WEISZ. All rights reserved.
The information included reflects the current state of development at the time of publication.
Due to continuous product improvement, specifications are subject to change without notice.