

OPERATING INSTRUCTIONS LEVEL PROBES

SERIES

26C, 26Y, 27Y
26X, 26Xi, 27X, 26KyX, 36KyX, 36XS
36XW, 36XW-CTD, 36XiW, 36XiW-CTD
46X

and various other custom and application specific series



KELLER Pressure

www.keller-pressure.com
info@keller-pressure.com

You can find details of other international KELLER Pressure subsidiaries and agents at www.keller-pressure.com/en/company/subsidiaries

1. GENERAL INFORMATION AND SAFETY INSTRUCTIONS



These operating instructions contain important information on using level probes correctly. The quick installation guide enclosed will be sufficient for experienced specialist personnel. Please read these operating instructions carefully for a detailed explanation of how to install the device and put it into operation. Follow the safety information in these operating instructions. You must also comply with national legislation, standards and regulations. These operating instructions form an integral part of the device and must always be accessible to the relevant staff.

DISCLAIMER

KELLER Pressure accepts no liability in case of improper use, damage or modification to the device or failure to observe this manual.

SUBJECT TO TECHNICAL ALTERATIONS!

1.1 SYMBOLS USED

SYMBOL	WARNING	NATURE AND SOURCE OF THE DANGER
	DANGER	Danger of death or injury to staff.
	WARNING	Potentially hazardous situation that could result in serious injuries or even death.
	NOTE	Tips and information for users.

1.2 INTENDED USE





- Level probes are used to convert a hydrostatic pressure into a standardised electrical signal.
- The level probes in the various series referred to have been developed for applications measuring the relative or absolute pressure of water or fill levels depending on the type of probe.
- Make sure that the device is suitable for your corresponding application. Please get in touch with your direct sales contact if you are unsure of anything.
- Please refer to the relevant data sheet and agreed specifications for information about the level probe's features.
- The technical specifications listed in the data sheet are only binding insofar as no other agreements have been made.
- The liquids used as measuring media must be compatible with the materials specified in the data sheet that come into contact with the media.

	DANGER	In the event of incorrect use!
--	--------	--------------------------------

1.3 STAFF QUALIFICATIONS

The product must only be assembled, installed, put into operation, operated, maintained, taken out of operation and disposed of by technically trained staff.

2. PRODUCT IDENTIFICATION

	SWISS MADE		
Type	PR-26Y	WH:	n.c.
Range	0...10 mH ₂ O	RD:	OUT/GND
Output	4...20 mA	BK:	+Vs
Supply	8...32 VDC	P/N	222625.0001
			
			15/22

Example of label



The label and the specifications on the product serve to identify it. The laser engraving or adhesive labels typically contain the following details:

- Product number
- Type designation
- Pressure range
- Output signal
- Supply voltage
- Electrical connections
- Production date

Products with a serial number display this on the metal housing.



3. MOUNTING

	DANGER	<p>Danger of death by electrocution, pressure discharge or leaking media!</p> <p>The device must only be installed on systems when they are not pressurised or connected to a power supply..</p>
	WARNING	<p>Danger of death in the event of incorrect installation!</p> <p>The device must only be installed by specialist personnel who have read and understood these operating instructions. Follow the national standards and safety regulations during the assembly and installation of the device.</p>

3.1 INSTALLATION AND SAFETY INFORMATION

- ✓ Only operate the level probe within its technical performance limits. You can find these on the label, in the data sheet or in the specifications. The device must not be operated for long periods in its overload range as this can damage it.
- ✓ The measuring medium must not be permitted to ice up.
- ✓ Ensure that the material used for the selected level probe, including the associated seals, is suitable for the medium to be measured.
- ✓ As standard, level probes are delivered without accessories such as mounting materials.
- ✓ Avoid electrochemical voltage potentials.
- ✓ Do NOT use the device to perform safety functions.
- ✓ Do not remove the packaging until immediately before installation to avoid damaging the diaphragm and/or the thread.
- ✓ The output signal may be dependent on the installation position. Always tighten the transmitter to the manufacturers' instructions
- ✓ Feed the cable output on pressure transmitters with cable into a dry terminal box.
- ✓ Avoid excessive tensile loads on the cable connections.
- ✓ Make sure the holes in the end cap are free from impurities/dirt.

3.2 MECHANICAL INSTALLATION

Installation of screwable level probe with pressure connection

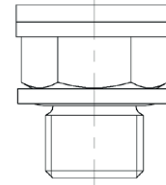

Example of a pressure connection

- ✓ Before installation, make sure that the seal surfaces on the device and the measuring point are clean and undamaged.
- ✓ Make sure that the seal is intact and is in its intended position. Check that the seal specifications correspond with the environment where it will be used.
- ✓ Make sure that you do not damage the diaphragm. Front-flush versions are to be treated with particular caution.
- ✓ Use suitable tools for installing the device.
- ✓ Tighten the device with the appropriate torque.

Follow the instructions below to ensure optimum installation:

1. Make sure that the seal surface seals correctly.
 2. Screw the device into the corresponding thread **by hand**.
 3. Using a suitable torque wrench on the spanner flats, tighten the device into place.
- ✓ Install the device in such a way that it cannot be exposed to any prohibited mechanical tension. This could have a negative effect on the zero point and/or the characteristic lines.

3.3 ELECTRICAL INSTALLATION

- ✓ Connect the device according to the electrical connections on the label or the specification.
- ✓ Prevent the cable from kinking.
- ✓ The following minimum bending radiuses must be adhered to when installing the cable:
 - Minimum bending radius for cables without capillary:**
Permanent installation: 6-fold cable diameter flexible usage: 12-fold cable diameter
 - Minimum bending radius for cables with capillary:**
15-fold cable diameter
- ✓ Ensure adequate earthing via the cable shield.
- ✓ Avoid potential differences between measuring and connection points. The resulting ground loops can lead to a defect of the level probe.
- ✓ For reference devices (relative pressure versions, PR), make sure there is adequate, dry ventilation.
- ✓ Make sure the cable is mounted securely, e.g. by using an additional retaining cable, for cable lengths > 50 m.



3.4 CONNECTION DIAGRAMS

2-wire / 4...20 mA

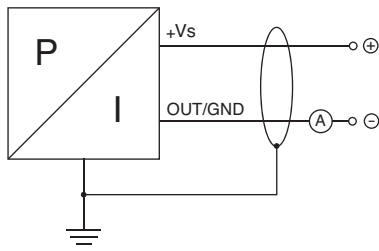

3-wire / 0...10 V / 0,5...4,5 V / etc.

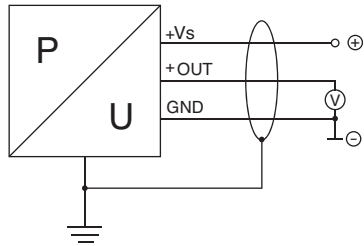

RS485

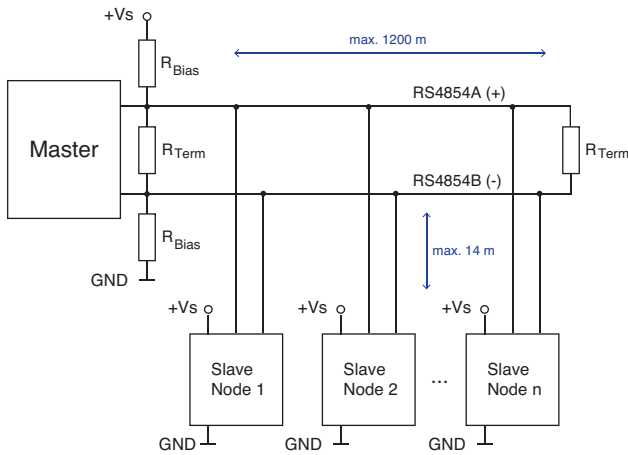

SDI-12

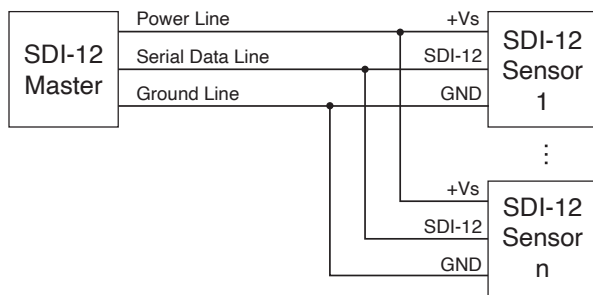

May vary for specific series. Please see the relevant **communication protocol** for additional information.

✓ You can find links to these via the relevant product on the KELLER Pressure website at www.keller-pressure.com.

4. COMMISSIONING

	WARNING	Before operating the device for the first time, check whether the device has been installed properly.
	WARNING	The device may only be operated by qualified personnel who have read and understood the operating instructions.
	WARNING	The device may only be operated within the specifications. See the technical data sheet or the agreed specifications.

5. TROUBLESHOOTING

Common installation errors:

DIFFERENT ZERO POINT SIGNAL
Possible cause:
<ul style="list-style-type: none"> Diaphragm damaged Ambient temperature too high / low
Action:
<ul style="list-style-type: none"> Contact the manufacturer and, if necessary, replace the device Keep to the permitted temperatures given in the data sheet
SIGNAL SPAN DECLINES / IS TOO LOW
Possible cause:
<ul style="list-style-type: none"> Mechanical overload Abrasive / aggressive medium; corrosion on the diaphragm / pressure connection
Action:
<ul style="list-style-type: none"> Contact the manufacturer
CONSISTENT OUTPUT SIGNAL WHEN PRESSURE CHANGES
Possible cause:
<ul style="list-style-type: none"> Mechanical overload Electrical fault
Action:
<ul style="list-style-type: none"> Replace the device; if the fault occurs again, contact the manufacturer
NO OUTPUT SIGNAL
Possible cause:
<ul style="list-style-type: none"> No supply voltage Device connected incorrectly Broken cable
Action:
<ul style="list-style-type: none"> Check the supply voltage Correct connection in accordance with the electrical connections
SIGNAL SPAN FLUCTUATING
Possible cause:
<ul style="list-style-type: none"> Source of EMC interference nearby (e.g. pump, frequency converter, etc.)
Action:
<ul style="list-style-type: none"> Remove the source of interference Shield the source of interference properly



6. SERVICING AND REPAIRS

6.1 MAINTENANCE

KELLER Pressure products require no maintenance and, if used in accordance with the specifications, are fault free.

6.2 RECALIBRATION

Depending on the conditions where the device is used, its zero point or amplification may change over time, causing an incorrect output signal.

We recommend that highly accurate devices with an accuracy of < 0,1 %FS are periodically recalibrated or have their zero point adjusted.

6.3 RETURNS

Register your return using our [online form](#) and describe the reason for the return as precisely as possible. After reviewing your request, you will receive a confirmation with all the necessary documents and detailed information on the further shipping process.

Important note: If your device has come into contact with harmful substances (e.g. chemical or hazardous substances), this must be specified when registering online. In the event of false information or insufficient decontamination, processing will be suspended until the situation has been clarified.

Clean the device thoroughly before each return and pack it securely for transport.

Return form: keller-pressure.com/en/rma

7. DISPOSAL

To dispose of the device, either return it to the supplier or dispose of it in a professional manner in accordance with the corresponding EU directive. Under no circumstances should the device be disposed of in household waste.

8. WARRANTY TERMS

The warranty is limited to 12 months from the date of delivery. KELLER Pressure guarantees that the products are free of manufacturing and material defects and that they comply with the specifications confirmed in writing.

9. EU DECLARATION OF CONFORMITY

The device supplied complies with the legal requirements. The relevant directives and harmonised standards are listed in the EU Declaration of Conformity applicable to the product. You can find the EU Declarations of Conformity by the relevant product at www.keller-pressure.com.



KELLER Pressure

www.keller-pressure.com
info@keller-pressure.com

You can find details of other international KELLER Pressure subsidiaries and agents at www.keller-pressure.com/en/company/subsidiaries



Subject to technical alterations.
450565.0123, Version 02/2026

