

Series 26KyX

Piezoresistive level probe with Kynar® diaphragm

Features

- The Kynar® diaphragm makes it ideal for sewage or wastewater
- RS485 interface can be combined with analog interface
- Analog interface scaleable by RS485 interface (turn-down)
- Modbus RTU protocol for process values and configuration
- For many years of maintenance-free operation

Technology

- Piezoresistive pressure sensor chip, insulated encapsulated
- Non-fouling diaphragm
- Robust stainless-steel housing
- Tried-and-tested mathematical signal compensation

Typical applications

- Hydrostatic pressure measurement
- Level measurement of sewage
- Level measurement in clarifiers

Accuracy

± 0,3 %FS

Total error band

± 0,5 %FS @ 0...50 °C

Pressure ranges

0...0,4 to 0...1 bar

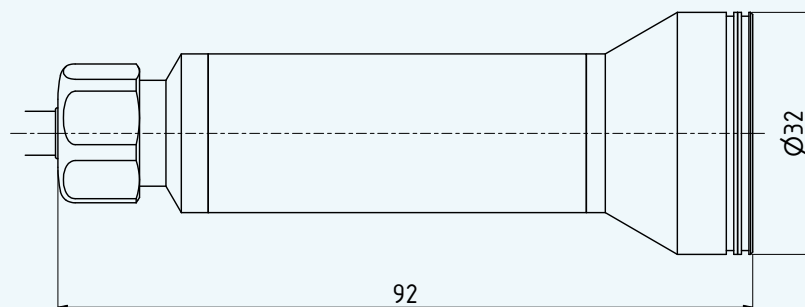

Series 26KyX – Specifications

Standard pressure ranges

Water column approx.	Relative pressure PR	Proof pressure
4	0,4	3
6	0,6	3
10	1	3
mH2O	bar rel.	bar
Analog interface also rangeable to other units	Reference pressure at atmospheric pressure	Based on reference pressure

Note: Wider pressure ranges available on request.

Performance

Pressure

Digital non-linearity	$\leq \pm 0,2$ %FS	Best fit straight line (BFSL)
Accuracy @ RT (20...25 °C)	$\leq \pm 3$ mbar	Non-linearity (best fit straight line, BFSL), pressure hysteresis, non-repeatability, zero point deviation and amplification deviation
Total error band (0...50 °C)	$\leq \pm 5$ mbar	Max. deviation within the compensated pressure and temperature range.
Compensated temperature range	0...50 °C	
Long-term stability	$\leq \pm 3$ mbar	
Position dependency	$\leq \pm 1,5$ mbar	Calibrated in vertical installation position with pressure connection facing downwards.
Resolution	20 μ bar	Digital
Signal stability	0,1 mbar	Digital noise-free
Pressure range reserve	$\geq \pm 10$ %	Outside the pressure range reserve, +Inf / -Inf is displayed. If there is an error in the device, NaN is displayed.

Temperature

Accuracy	$\leq \pm 1,5$ °C	The temperature is measured on the pressure sensor (silicon chip) that sits behind the metallic separating diaphragm.
Optional	$\leq 0,1$ °C	The temperature is also measured by a Pt1000 sensor behind the pressure transducer.
Resolution	$\leq 0,01$ °C	
Internal measurement rate	≥ 10 Hz	
Note	The data applies within the compensated temperature range.	

Series 26KyX – Specifications

Electrical data

Connectivity	digital	2-wire + digital	3-wire + digital
Analog interface		4...20 mA	0,1...2,5 V
Digital interface	RS485	RS485	RS485
Voltage supply	3,2...32 VDC	8...32 VDC	3,2...32 VDC
Voltage supply with lightning protection (advanced surge protection)	4,5...32 VDC	10...32 VDC	N/A
Power consumption (without communication)	< 8 mA	3,5...22,5 mA	< 8 mA
RS485 voltage insulation	± 32 VDC	± 18 VDC	± 32 VDC
Note	Disturbance of the 4...20 mA signal occurs during communication via the digital interface. 3-wire types are suitable for simultaneous operation of the analog and digital interface.		

Start-up time (power supply ON)	< 250 ms
Overvoltage protection and reverse polarity protection	± 32 VDC
GND case insulation	> 10 MΩ @ 300 VDC

Analog interface

Load resistance	< (U - 8 V) / 25 mA	2-wire
	> 5 kΩ	3-wire
Limiting frequency	≥ 300 Hz	2-wire
	≥ 1000 Hz	3-wire
Note	Filter properties can be adjusted by the customer.	

Digital interface

Type	RS485	Half-duplex
Communication protocols	Modbus RTU	
	KELLER bus protocol	Proprietary
Identification	Class.Group: 5.24	Standard settings: bus address 1, baud rate 9600 bit/s.
Unit of pressure	bar	
Unit of temperature	°C	Other default settings available on request. Can be reconfigured via software by the customer later.
Data type	Float32 and Int32	
Baud rates	9600 and 115,200 bit/s	
Cable lengths	up to 1,2 km	

Electrical connection

Cable	polyethylene (PE) ø 5,8 mm	Integrated capillary
Standard cable lengths	5 m, 10 m, 15 m, 25 m	Others available on request.

Electromagnetic compatibility

CE conformity as per 2014/30/EU (EMC)	EN IEC 61326-1 / EN IEC 61326-2-3 / EN IEC 61000-6-1 / EN IEC 61000-6-2 / EN IEC 61000-6-3 / EN IEC 61000-6-4	
Surge protection in accordance with EN 61000-4-5	Standard	Line-line: 50 A @ 8/20 μs
		Line-CASE: 200 A @ 8/20 μs
Lightning protection (advanced surge protection) in accordance with EN 61000-4-5	Optional	Line-line: 10 kA @ 8/20 μs
		Line-CASE: 2 kA @ 8/20 μs

Series 26KyX – Specifications

Mechanical data

Materials in contact with media

Housing	Stainless steel AISI 316L	
Pressure transducer separating diaphragm	PVDF (Kynar®)	
Pressure transducer seal (internal)	None	
Cable gland seal (internal)	FKM	Others available on request
Cable sheath	Polyethylene (PE)	Others available on request

Other materials

Pressure transducer oil filling	Silicone oil
---------------------------------	--------------

Further details

Pressure connection	None	See Dimensions and variants
Diameter × length	ø 32 mm × approx. 92 mm	
Weight	approx. 150 g	

Environmental conditions

Media temperature range	-10...60 °C	Icing not permitted
Ambient temperature range	-10...60 °C	
Storage temperature range	-10...60 °C	
Protection	IP68	Cable gland
Vibration resistance	10 g, 10...2000 Hz, ±10 mm	IEC 60068-2-6
Shock resistance	50 g, 6 ms	IEC 60068-2-27

Series 26KyX – Dimensions and variants

Electrical connections

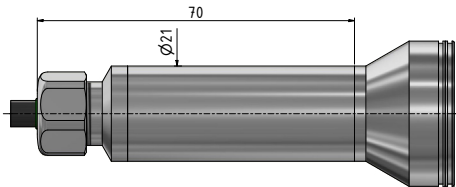

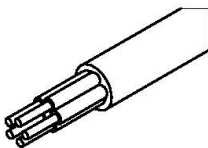
Cable gland	2-wire		3-wire	
Cable	4...20 mA		0,1...2,5 V	
	WH	OUT/GND	WH	GND
	RD	n.c.	RD	+OUT
	BK	+Vs	BK	+Vs
	BU	RS485A	BU	RS485A
	YE	RS485B	YE	RS485B
	Shield on CASE		Shield on CASE	

Available pressure connections

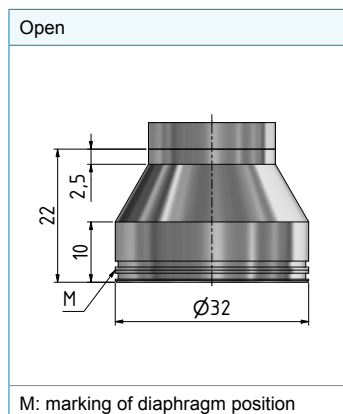

Customised configurations on request

- Other pressure ranges available on request
- Extended lightning protection
- Integration of application-specific calculations

Examples of similar products

- Series 36XW: Level probe with excellent accuracy
- Series 26KyXi: Piezoresistive level probe with Kynar® diaphragm and SDI-12 interface

Series 26KyX – Software, scope of delivery and accessories

Modbus interface

The X-line products have a digital interface (RS485 half-duplex), which supports the MODBUS RTU and KELLER bus protocols.

Details of the communication protocols can be found at www.keller-pressure.com. To integrate the communication protocol into your own software, documentation, a Dynamic Link Library (DLL) and various program examples are available.

Interface converters

The connection to a computer is established via an RS485-USB interface converter. To ensure smooth operation, we recommend the K-114 with the corresponding mating plug, robust driver module, fast RX/TX switching and connectable bias and terminating resistors.

“CCS30” software

The CCS30 software has no licence costs and is used to perform configurations and record measured values.

Measurement recording

- Live visualisation
- Configurable measuring and storage interval
- Export function
- Parallel recording in bus operation
- Up to 100 measured values per second

Configuration

- Call up of information (pressure and temperature range, software version, serial number etc.)
- Readjustment of zero point and amplification
- Rescaling of analog output (unit, pressure range)
- Adjustment of low-pass filter
- Selection of instrument address and baud rate

Scope of delivery

Calibration certificate



Accessories

Interface converter



K-114

- Analog measurement 0...10 V and 4...20 mA
- 12 V measuring device supply via USB
- USB interface galvanically isolated
- Bias and terminating resistors can be activated